

Motwane Entrance Control Systems





Product Highlights

- ✓ Multilingual operation
- ✓ Automatic built in test and self diagnosis
- ✓ Secure access Key
- ✓ Threat alert and material classification
- ✓ Auto archiving
- ✓ Energy saving design
- ✓ One key turn off
- ✓ Drugs and explosives inspection
- ✓ Indication of the date and time
- ✓ Baggage counter

Configuration

- ✓ Monitor : One 21.5-inch LCD monitor, 1920*1080, No console desk
- ✓ RAM : 1GB
- ✓ Keyboard : Special designed
- ✓ System : Embedded Linux operating system, multi core ARM, stable and reliable
- ✓ Electric Roller : Single-Phase

X-RAY BAGGAGE

SCANNERS - MBS 100100



To maintain the safety and security of a building, X-Ray Baggage Scanners play a vital part in detecting threats, such as potential weapons or prohibited material. Motwane's scanners not only ensure clear, easy-to-interpret visuals about the inner lives of bags and suitcases, but also offer usage flexibility through their compact and mobile design. Implemented across a wide range of sectors and industries – such as malls, hospitals, residential and commercial complexes, airports, movie theatres, and data centres, among others – Motwane offers its X-Ray Baggage Scanners in different models and sizes to address every possible requirement with the most accurate precision.

The ideal solution for



Hotels



Airports



Railways



Comercial Complex

Built for you:

- Lightweight & Durable
- Low Vibration
- Easy to Use
- Excellent Image Resolution





TECHNICAL DETAILS

X-RAY BAGGAGE SCANNERS - MBS 100100

MODEL	MBS 100100
UNIT WEIGHT	940 KGS
UNIT SIZE (MM)	3629(L) x 1295(W) x 1916(H)
GROSS WEIGHT (KGS)	1100 KGS
PACKING SIZE	#1: 285*142*212cm #2: 75*65*99cm
TUNNEL SIZE (MM)	1000(L) x 1000 (W)
CONVEYOR SPEED (M/S)	0.22
CONVEYOR HEIGHT (MM)	341
CONVEYOR MAX LOAD (KGS)	200
X RAY DOSE PER EACH INSPECTION	≤ 3.5μGy
X RAY LEAKAGE	<1μGy/h at any point 5 centimeters outside the external surface
PENETRATION	34 mm steel
WIRE RESOLUTION	AWG36
PENETRATION RESOLUTION	AWG30
SPATIAL RESOLUTION	Horizontal:dia 2.0mm, Vertical: dia 2.0mm
POWER CONSUMPTION	Max. 1KW
NOISE	<60 dB
FILM SAFETY	Guarantee ASA/ISO1600 Film
X-RAY GENERATOR (SINGLE)	
ANODE VOLTAGE	160 KV
RAY DIRECTION	Downward
COOLING / DUTY CYCLE	Sealed oil cooling /100%

**SOFTWARE****X-RAY BAGGAGE SCANNERS - MBS 100100****IMAGING SYSTEM****X-RAY SENSOR**

L-Shaped Photodiode Array, 12bit deep

IMAGES PROCESS

24bit real time processing, 4colors analysis, Images displayed marked date andID No.,

Count the number of bags

IMAGE DISPLAY

High resolution of 1920 x 1080 pixel; Image Grey Level: 65536

IMAGE ENHANCEMENT

1-32 times enlargement continuity, Color/BW, negative, high/low penetrationenhancement,

brightening, darkening, gray level scan, super enhancement,elimination of organics/inorganics,

local enhancement, pseudo color processing,edge enhancement, etc.

**EXPLOSIVES & NARCOTICS
DETECTION**Suspicious organics highlight(atomic number $Z_{eff}=7,8,9$)**SUSPECIOUS ALARM**

Alarm and box line the suspicious objects including hard to penetrate material,explosives and drugs

**THREAT IMAGE
PROJECTION (TIP)**

Inserting fictional, but realistic images of threat items into baggage duringscreening operation,

for maintenance of vigilance, as well as training andassessment of image identification capability

IMAGE RECALL

30 images recallable

IMAGE ARCHIVE

Up to 10,000 images stored automatically, enable transferring to USB disk, andconverting to

JPG format

MISCELLANEOUS FUNCTIONS

Time/date display, counters, user management, system-on/X-ray-on timers,power on self test, built-

in diagnostic facilities, dual-direction scanning, systemlog, system standby and stimulant training, etc.

OPTIONS

Inteligent roller, network, etc.



SOFTWARE

X-RAY BAGGAGE SCANNERS - MBS 100100

OPERATING ENVIRONMENT

OPERATION TEMPERATURE/HUMIDITY	5°C-40°C / 0%-90% (Non-condensing)
STORAGE TEMPERATURE/HUMIDITY	-20°Cto 60°C / 10%-90% (Non-condensing)
OPERATION POWER	220VAC (±10%) 50±3Hz (Options: 110-120V, 230-240V, 60Hz)
STABILIZER AND UPS	Optional

GA LAYOUT

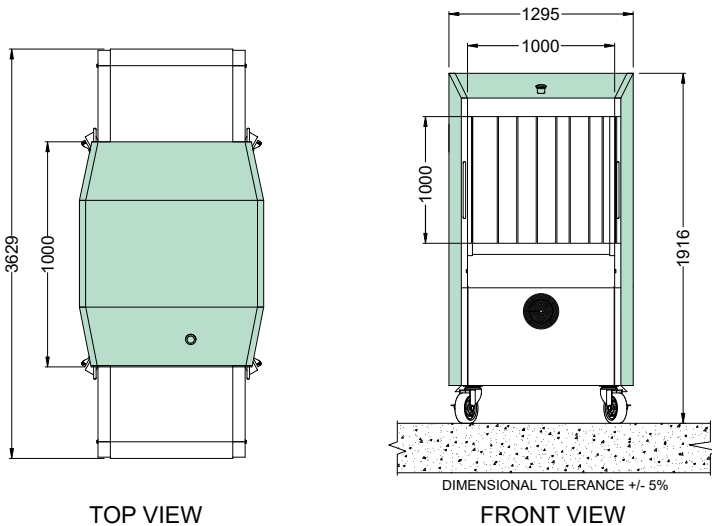

TOP VIEW

FRONT VIEW

Disclaimer:

The product images shown are for illustration purposes only and may not be an exact representation of the product. Motwane reserves the right to modify product images and specifications at any time without notice in line with our continuous product improvement and upgrades.

Contact Details

The MOTWANE Manufacturing Company Private Limited



Gyan Baug, Nashik Road,
422101 Maharashtra, India



www.motwanesecuritysystems.com



Toll-free number:
1800 233 7766



<https://www.linkedin.com/company/motwanemanufacturing>

Scan the QR code to visit
Motwane's new website



Disclaimer : The product images shown are for illustration purposes only and may not be an exact representation of the product. Motwane reserves the right to modify product images and specifications at any time without notice.